

DECKE ÜBER UNTERGESCHOSS TEIL 1  
UNTERE BEWEHRUNG, M 1:50

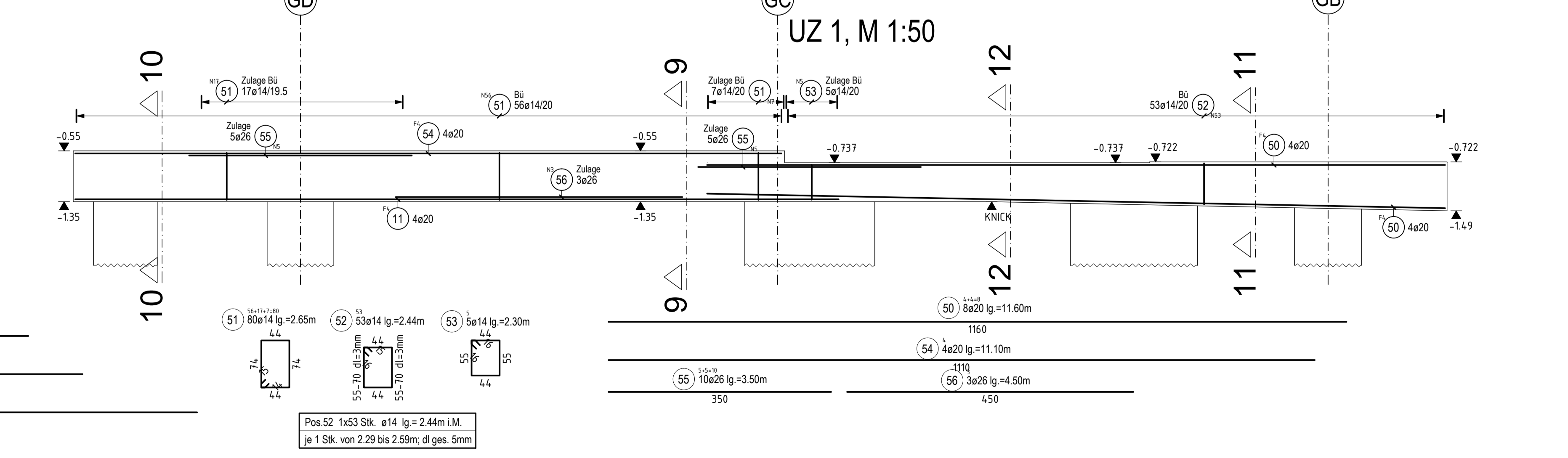
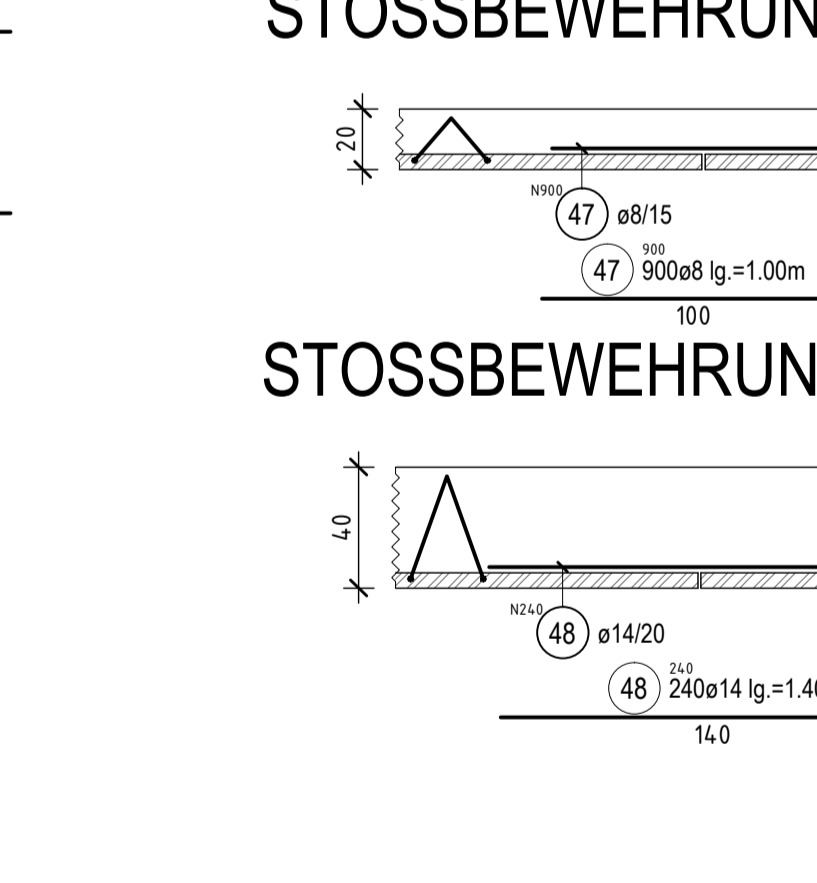
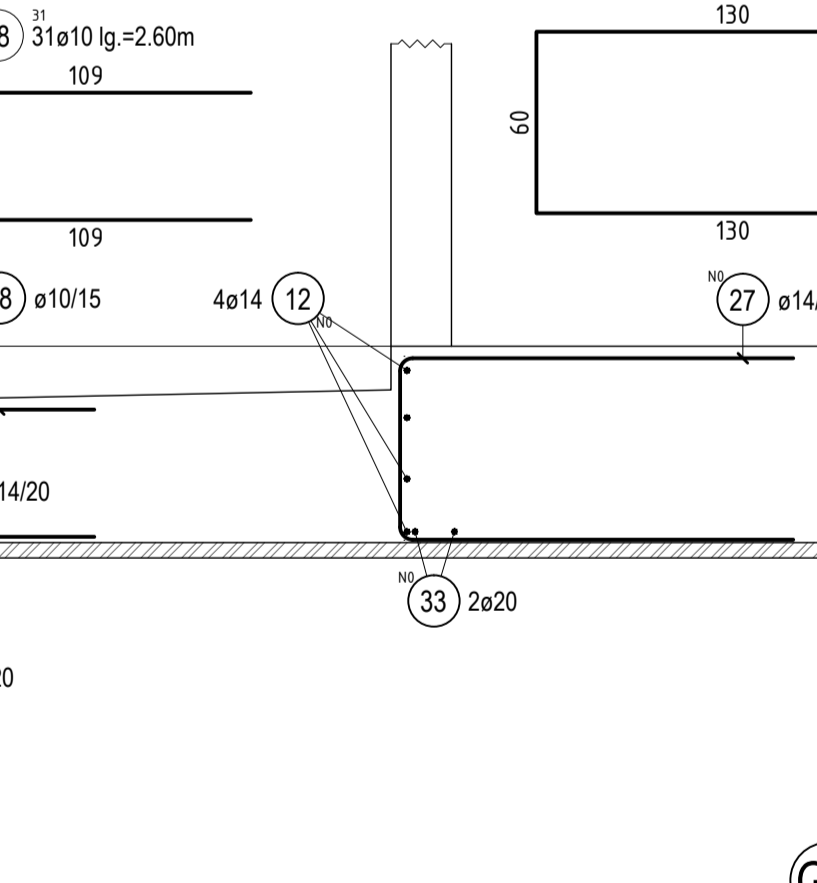
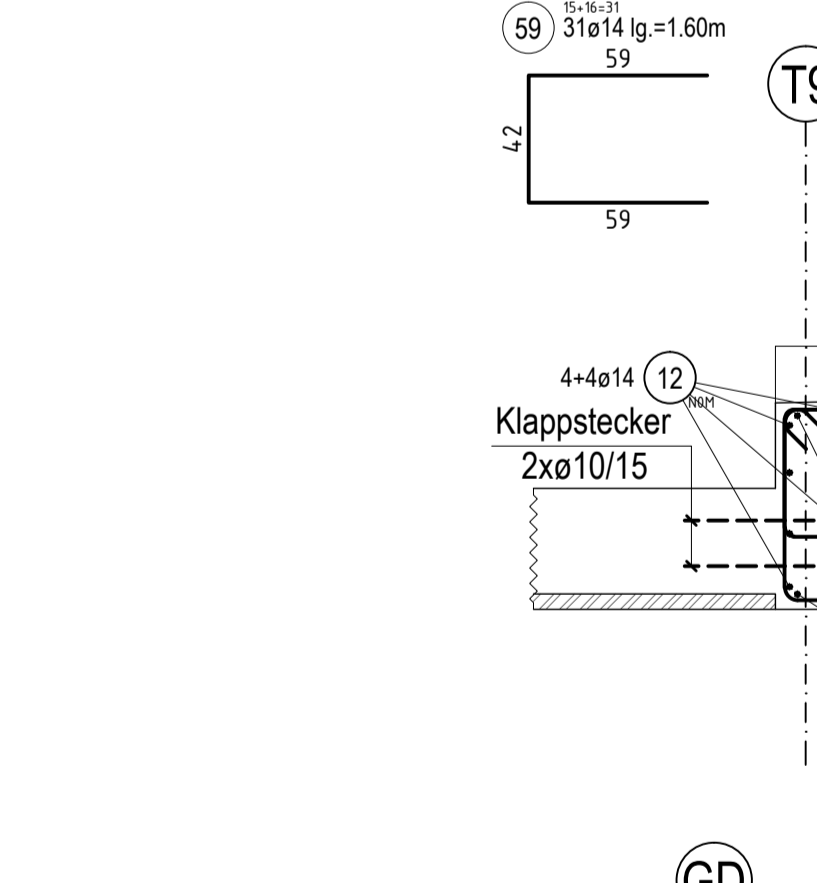
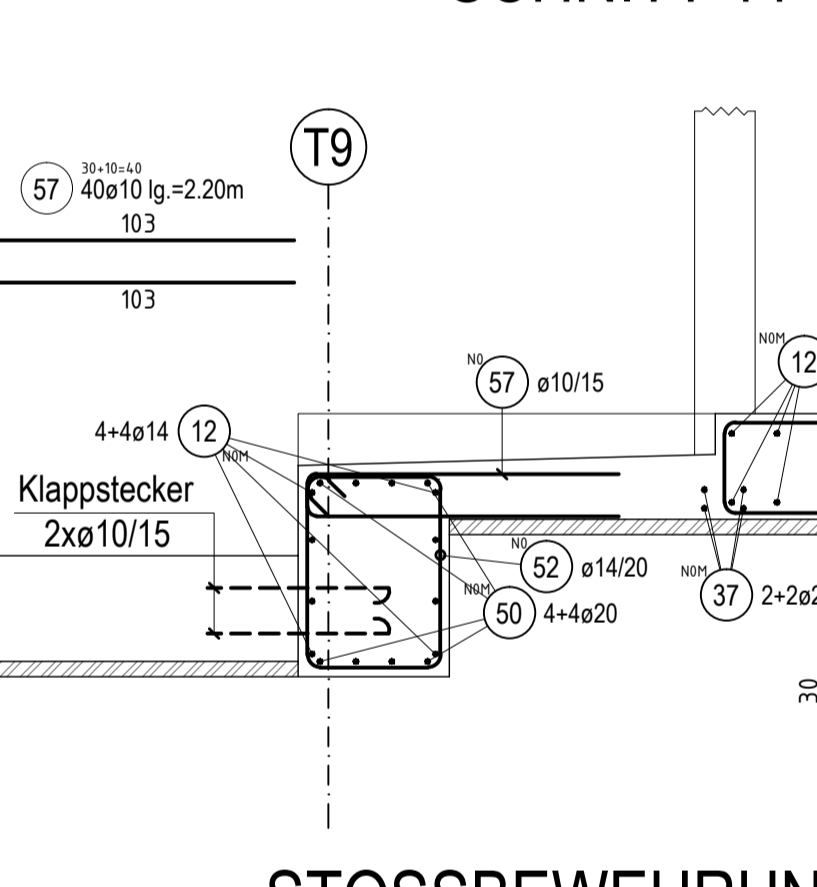
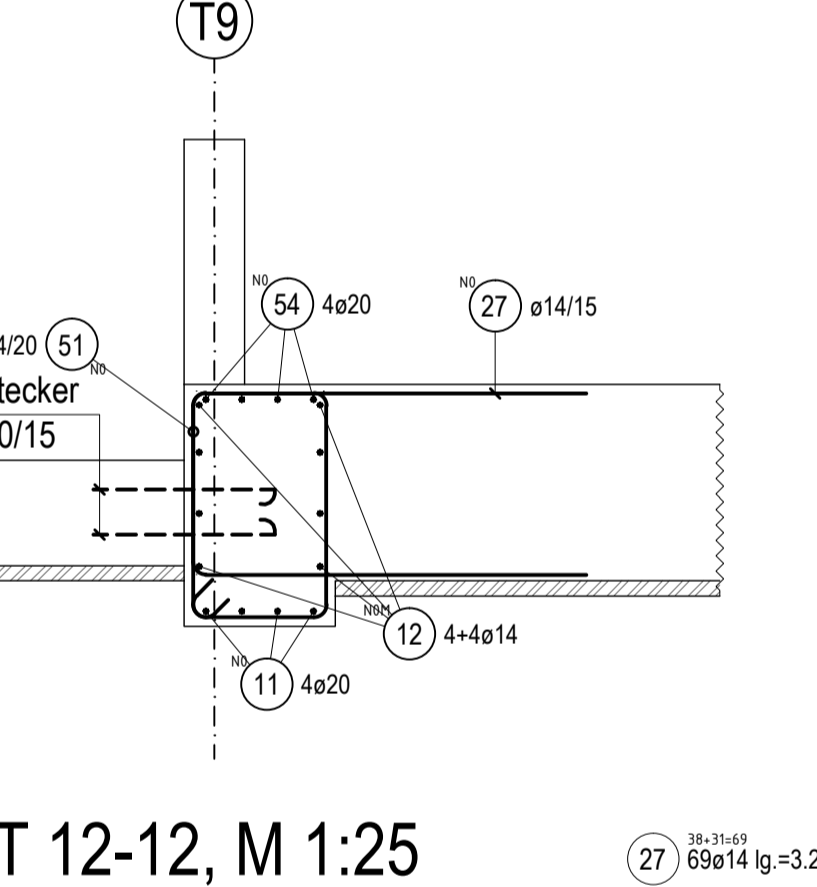
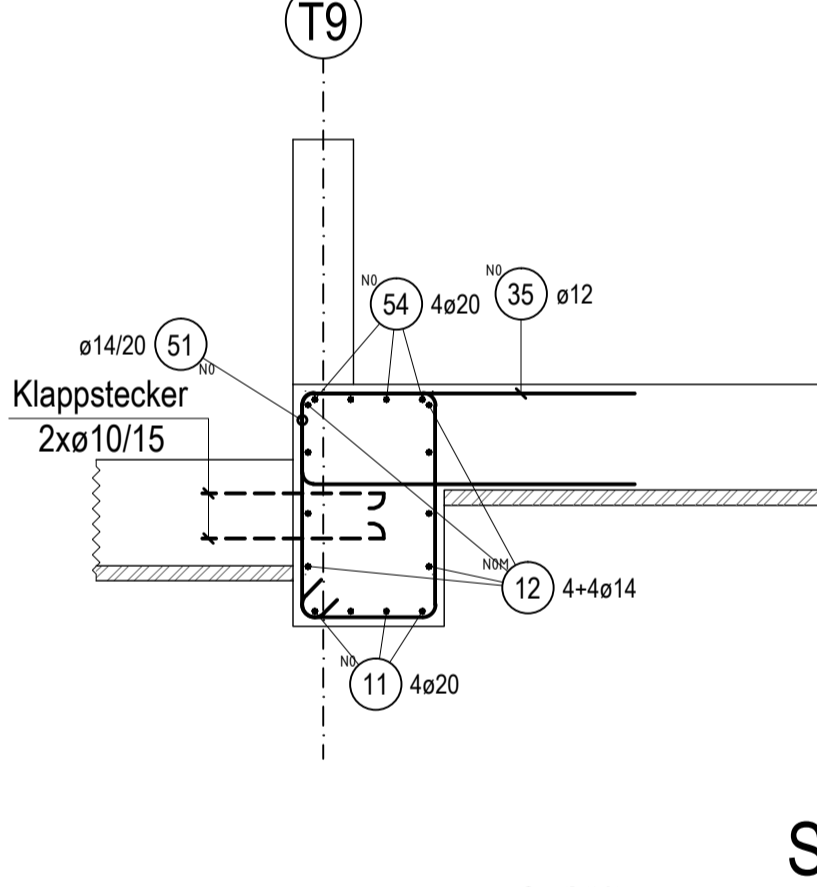
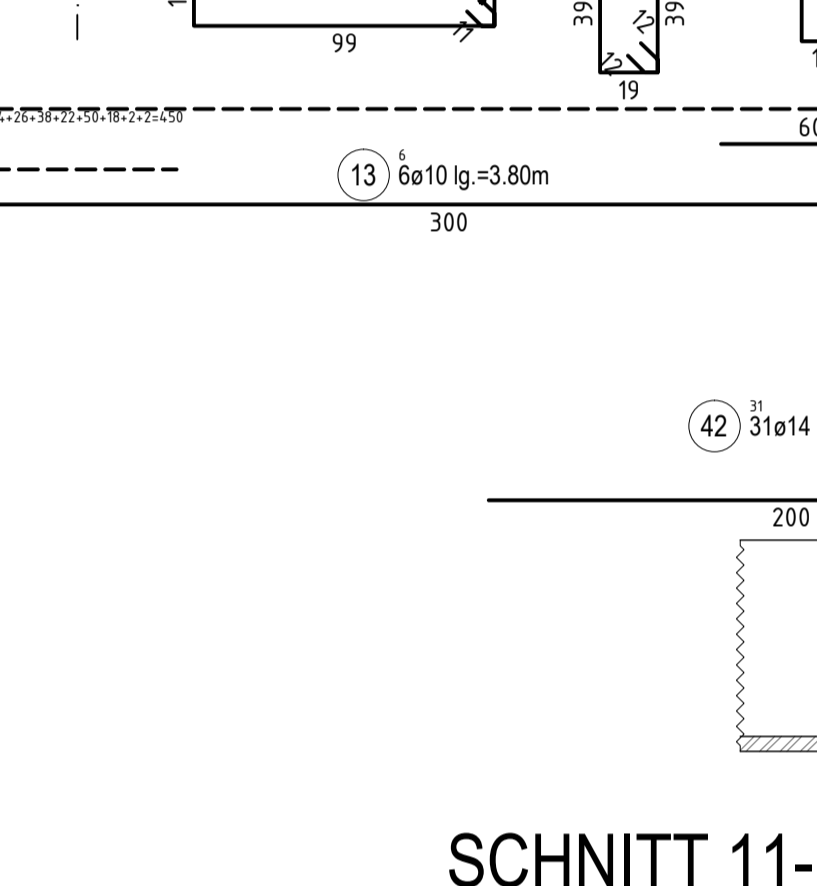
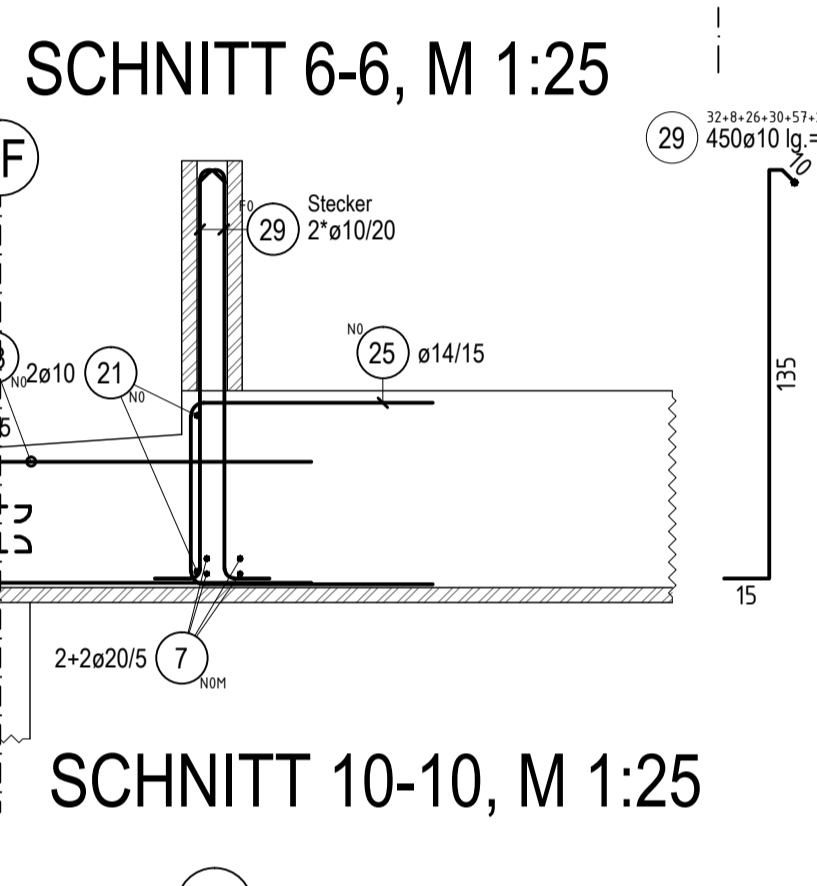
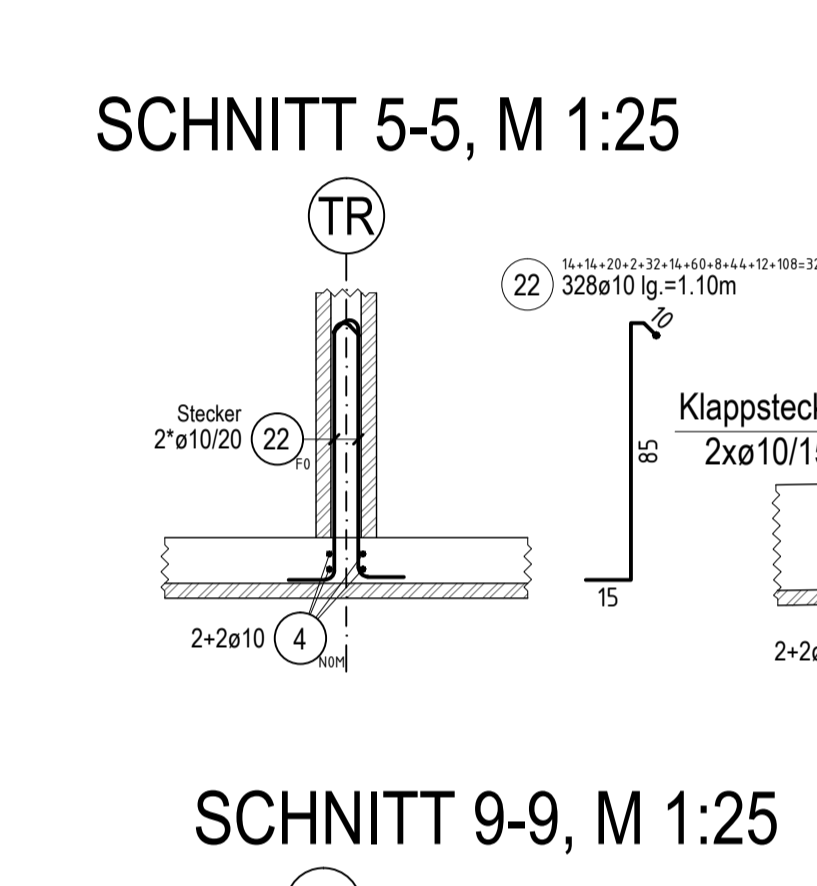
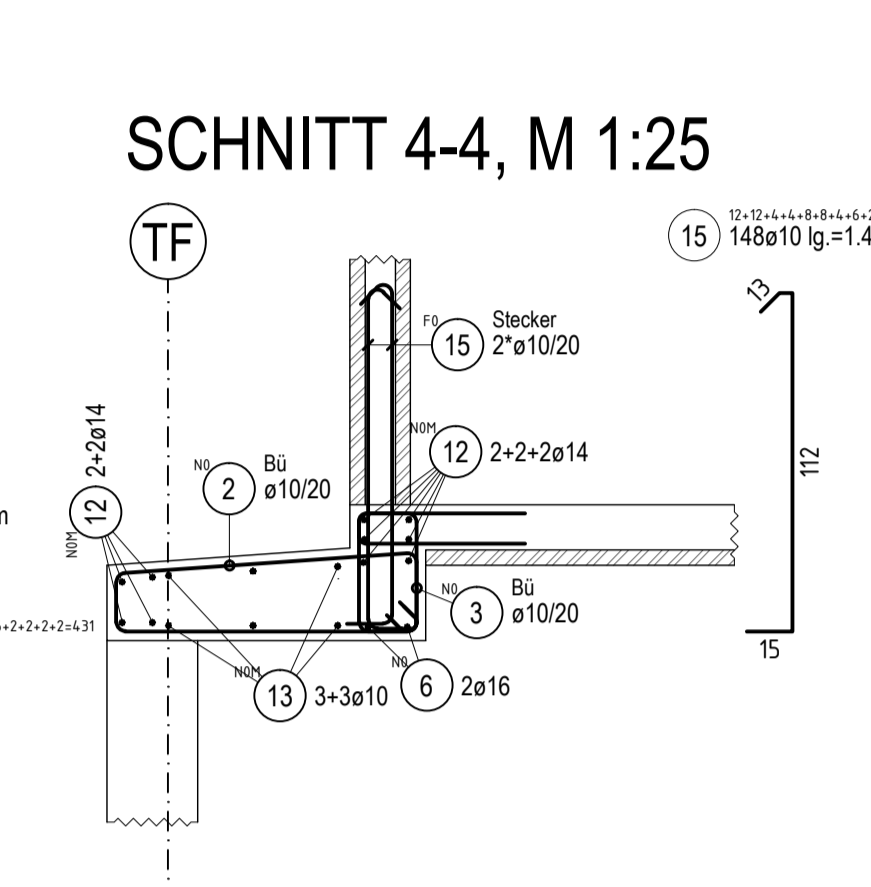
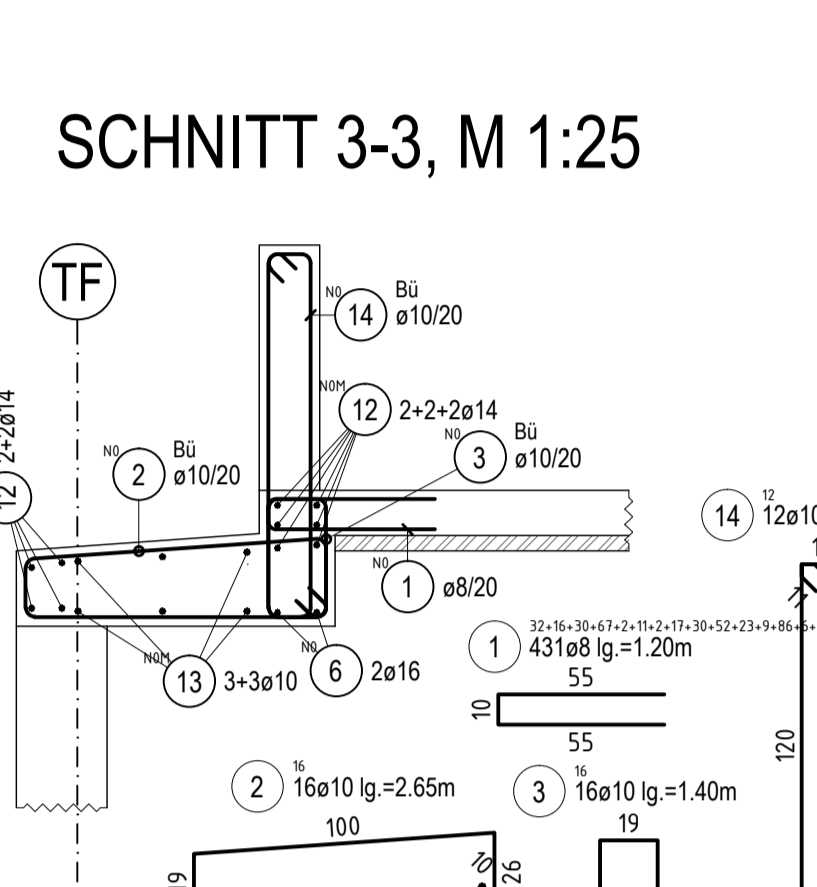
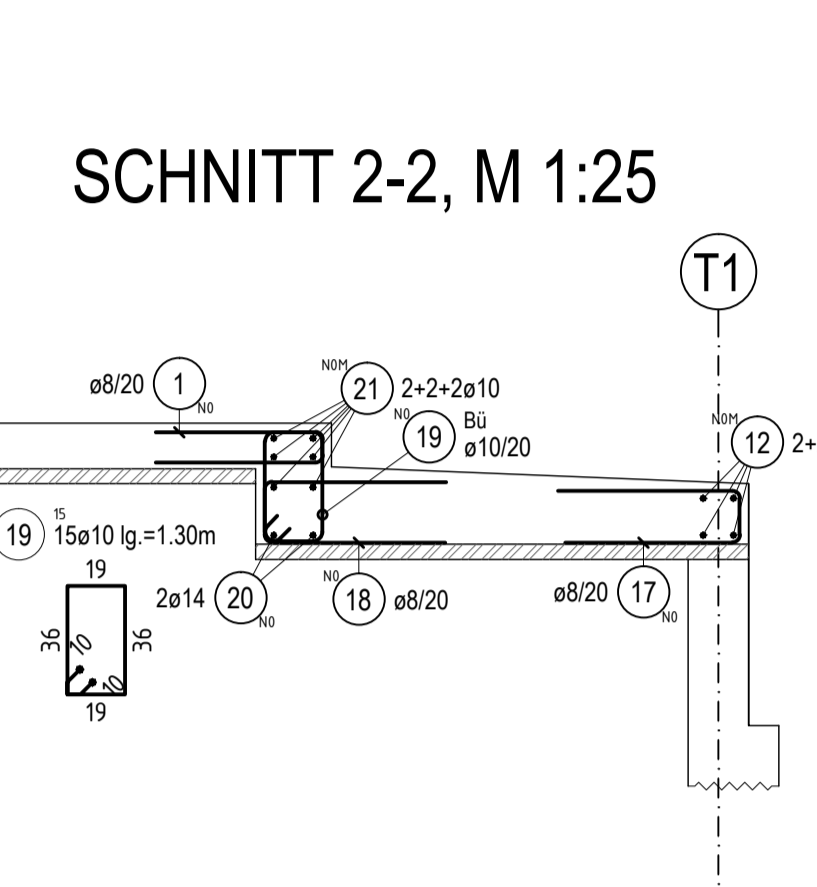
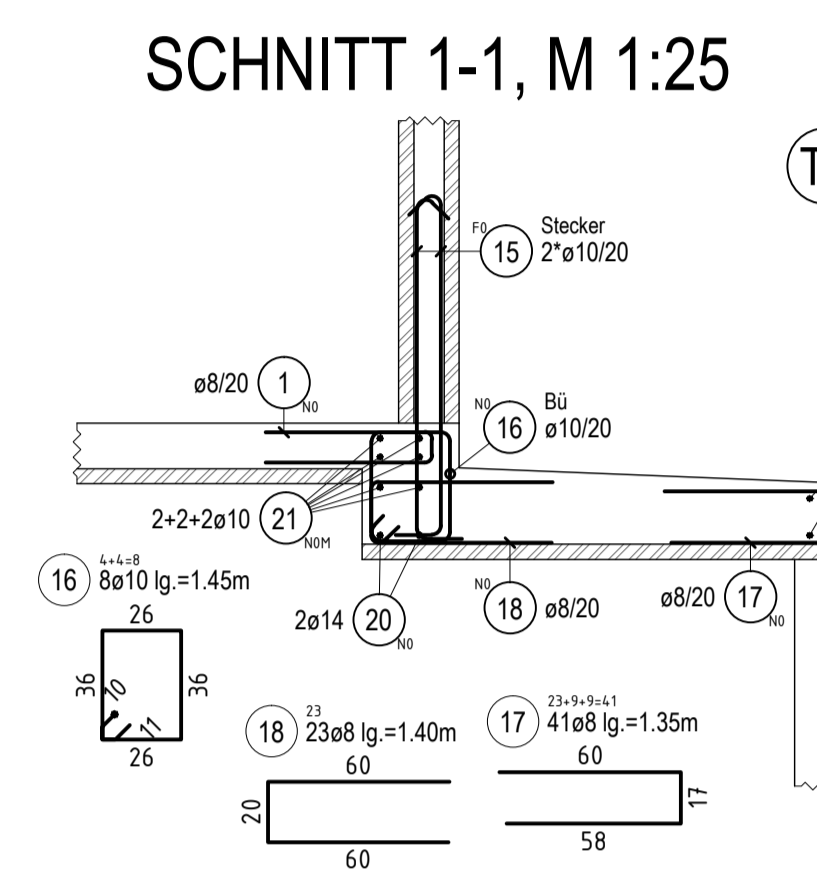
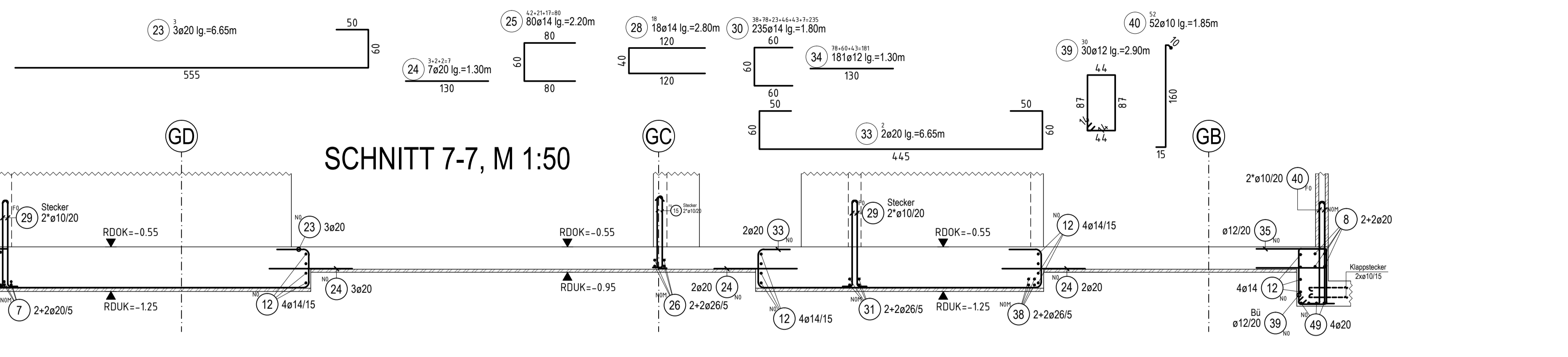
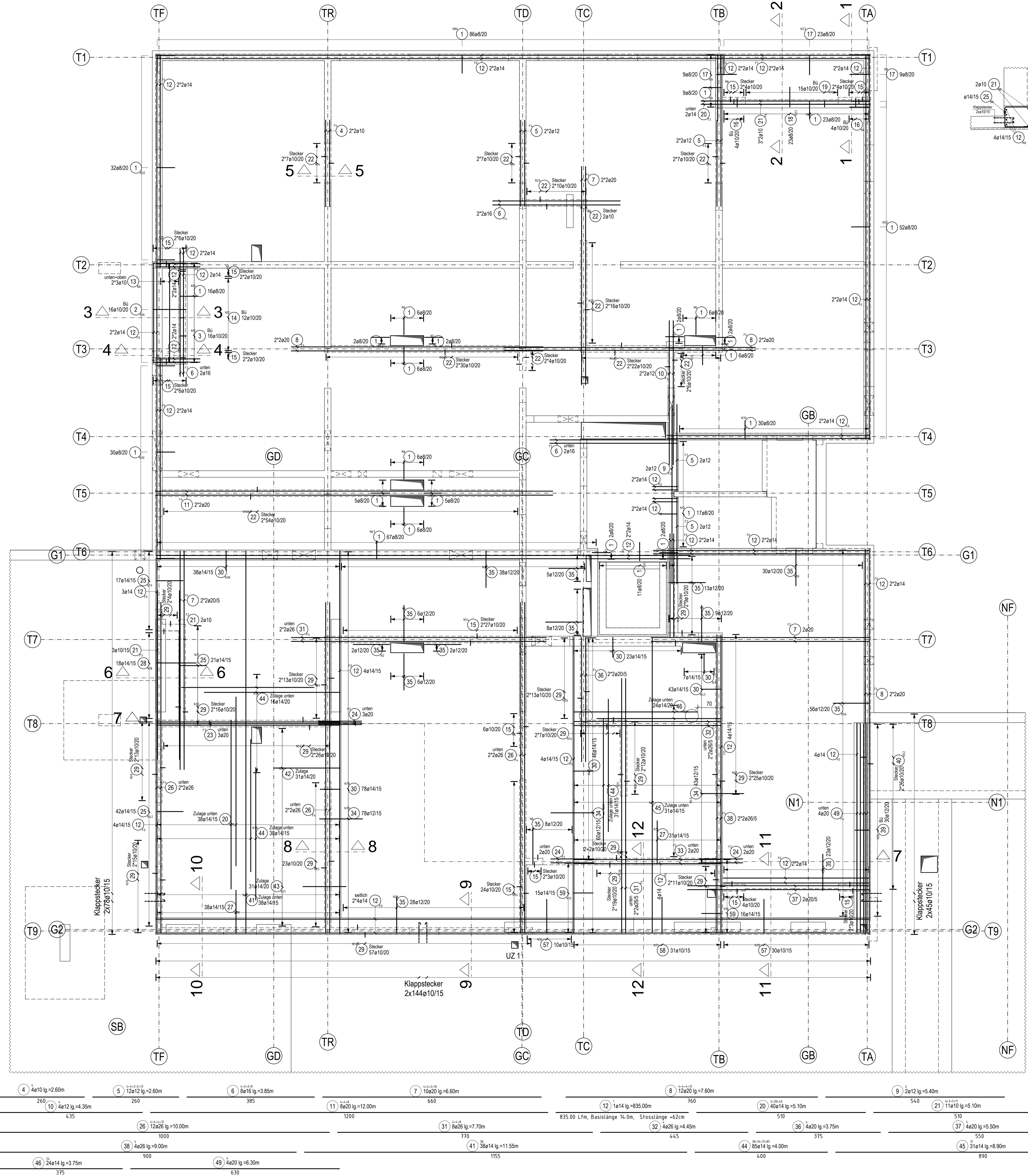

MENGENLISTE - STABSTAHL											
Pos.	Stk.	Ø [mm]	Länge [m]	Summe [Lfm]	Gewicht [kg]	Pos.	Stk.	Ø [mm]	Länge [m]	Summe [Lfm]	Gewicht [kg]
1	431	8	1.20	517.20	204.29	31	8	26	7.70	61.60	256.87
2	16	10	2.65	42.40	26.16	32	4	26	4.45	17.80	74.23
3	16	10	1.40	22.40	13.82	33	2	20	6.65	13.30	32.85
4	4	10	2.60	10.40	6.42	34	181	12	1.30	235.30	208.95
5	12	12	2.60	31.20	27.71	35	234	12	2.50	585.00	519.48
6	8	16	3.95	31.60	48.68	36	4	20	3.75	15.00	37.05
7	10	20	6.60	66.00	163.02	37	4	20	5.50	22.00	54.34
8	12	20	7.60	91.20	225.26	38	4	26	9.00	36.00	150.12
9	2	12	5.40	10.80	9.59	39	30	12	2.90	87.00	77.26
10	4	12	4.35	17.40	15.45	40	52	10	1.85	96.20	99.36
11	8	20	12.00	96.00	237.12	41	38	14	11.55	438.90	531.07
12	1	14	835.00	835.00	1010.35	42	31	14	3.20	99.20	120.03
13	6	10	3.80	22.80	14.07	43	31	14	1.30	40.30	48.76
14	12	10	2.90	34.80	21.47	44	85	14	4.00	340.00	411.40
15	148	10	1.40	207.20	127.84	45	31	14	8.90	275.90	353.84
16	8	10	1.45	11.60	7.16	46	24	14	3.75	90.00	108.90
17	41	8	1.35	55.35	21.86	47	900	8	1.00	900.00	355.50
18	23	8	1.40	32.20	12.72	48	24	14	2.65	212.00	256.52
19	15	10	1.30	19.50	12.03	49	4	20	6.30	25.20	62.24
20	40	14	5.10	204.00	246.84	50	8	20	11.60	92.80	229.22
21	11	10	5.10	56.10	34.61	51	80	14	2.65	212.00	256.52
22	328	10	1.10	360.80	222.61	52	53	14	2.44	129.32	156.48
23	3	20	6.65	19.95	49.28	53	5	14	2.30	11.50	13.92
24	7	20	1.30	9.10	22.48	54	4	20	11.10	44.40	109.67
25	80	14	2.20	176.00	212.96	55	10	26	3.50	35.00	142.95
26	12	26	10.00	120.00	500.40	56	3	26	4.50	13.50	56.30
27	69	14	3.20	220.80	267.17	57	40	10	3.20	88.00	54.30
28	18	14	2.80	50.40	60.98	58	31	10	2.60	80.60	49.73
29	450	10	1.60	720.00	444.24	59	31	14	1.60	49.60	60.02
30	235	14	1.80	423.00	511.83						

Stahlgruppe: B500A  
Betonart: C25/30/XC1  
Betondeckung: 3.00m  
Anzahl Ausführungen: 1

DIM	LFM	KG/LFM	KG
26	283.90	4.170	1183.86
20	494.95	2.470	1222.53
16	300.80	1.590	469.68
14	3931.92	1.210	4757.62
12	966.70	0.888	858.43
10	1772.80	0.617	1093.82
8	1504.75	0.395	594.38

BEWEHRUNGSGEHALT kg/m³  
Gesamtgewicht Stabstahl = 9759.32 kg  
Gesamtgewicht = 9759.32 kg  
Betonvolumen = 205.73m³  
Bewehrungsgehalt = 47.43 kg/m³

MATERIALGÜTEN:		BETONDECKUNG	
BETON:	C25/30/XC1	MINDEST	3.00m
STABSTAHL:	B500A	AUSWEICHEN	3.00m
MATTEN:	M50	IN LANGRICHTUNG	400m
		IN QUERRICHTUNG	400m

LEGENDE: 1 STABSTAHL-POSITION, 2 MATTENBEREICHE

BERMerkungen:  
1. BELEGPLÄNE SIND AUSGEFÜHRT.  
2. VERTEILUNGSGEBIETE NICHT ANGEZEIGT, STOSSE BEI ERHALTUNG DER ANGEZEIGTEN BEREIFE VERSETZT.  
3. VERHÄNGNISSE, AUFHÄNGEGERÄTE, WÄRMELÄMME, SCHALLEN UND SCHLÄNGEN SIND NACH DEMER PLANZUG BEW. DREHEND IN WEISUNG DER BEWEHRUNG ANZUBRINGEN.

PLANSTATUS:  
VORLAGE: VERLEBUNGSSYSTEM  
ALLES: AUSFÜHRUNG  
FREI ZUR AUSFÜHRUNG, WENN ZUGEHÖRIGE SCHALPLÄNE AUSFÜHRUNGSPLÄNE SIND.

DIESER PLAN IST NUR DANN GÜLTIG, WENN DIE ZUGEHÖRIGEN SCHALPLÄNE AUSFÜHRUNGSPLÄNE SIND.

PLANNUMMER	PROJEKT	DATUM	PLANNITEL
SB 01-1-1	AZ	09.07.2014	DECKE ÜBER UNTERGESCHOSS TEIL 1

STADT	STRASSE	ORT	BAUABT.
WIEN	MUSTERGASSE 123	A-1230	WIEN

MUSTERHAUS  
MUSTERGASSE 123  
A-1230 WIEN

Auftraggeber:   
Ausführungsplanung:   
Planverfasser:   
Planart: BEWEHRUNG, Planstatus: AUSFÜHRUNG  
Planobjekt: DECKE ÜBER UNTERGESCHOSS TEIL 1 UNTERE BEWEHRUNG  
Datum: 09.07.2014, Format: 1:15 m², A-Nr.: 12345  
Maßstab: 1:25, 1:50, PL: AZ, Stk: AZ, Konstruktion: AZ  
SB 01-1-1-U103